

I B. Tech II Semester Regular/Supplementary Examinations, April/May - 2018
BASIC ELECTRICAL AND ELECTRONICS ENGINEERING
 (Com. to ME, AE, AME, Min.E, MET)

Time: 3 hours

Max. Marks: 70

- Note: 1. Question Paper consists of two parts (**Part-A** and **Part-B**)
 2. Answering the question in **Part-A** is Compulsory
 3. Answer any **FOUR** Questions from **Part-B**

PART - A

1. a) When three capacitors 1F each are connected in series, what is the equivalent capacitance. (2M)
- b) What is the necessity of three point starter in a dc motor? (2M)
- c) Define magnetizing and no-load components of a single phase transformer. (2M)
- d) Explain the relation between motor speed and supply frequency in a synchronous motor. (2M)
- e) Define slip of an Induction motor. (2M)
- f) Define the ideal characteristics of OP-AMP. (2M)
- g) What is the operating point of transistor amplifier? (2M)

PART - B

2. a) Calculate V_o and I_o in the circuit shown in figure 2(a). (7M)

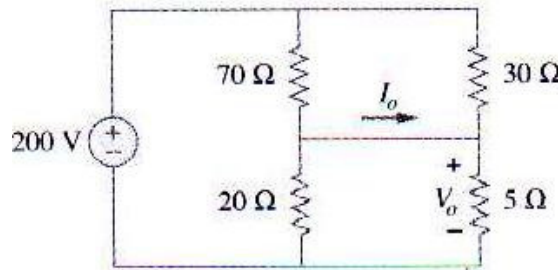

Figure 2(a)

- b) Find the equivalent resistance between terminals x-y in the resistance network shown in figure 2(b) by using Y- Δ transformation. (7M)

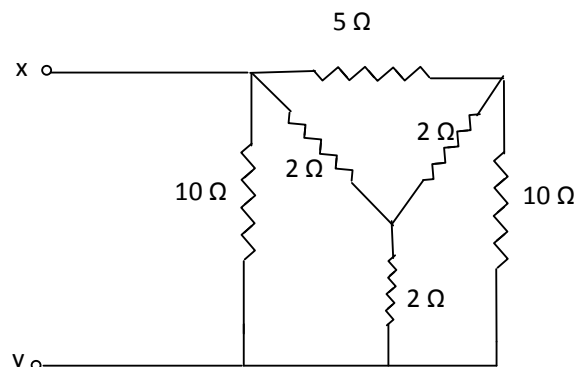
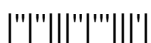
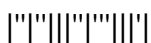

Figure 2(b)



3. a) Explain the principle of operation of a dc generator and derive its emf equation. (9M)
- b) A 220-V, shunt motor, running at 700 rpm, has an armature resistance of 0.45Ω (5M) and takes an armature current of 22 A. What resistance should be placed in series with the armature to reduce the speed to 450 rpm?
4. a) Describe how open-circuit and short circuit tests are performed on a single phase (8M) transformer.
- b) A single- phase, 230-V/110-V, transformer has iron loss of 100 W at 60 Hz. (6M) Determine the hysteresis and eddy-current losses at 50 Hz.
5. a) Draw and explain the torque-slip characteristic of an induction motor. (7M)
- b) With neat sketches, explain the classification of alternators. (7M)
6. a) Derive the efficiency and ripple factor of half wave rectifier. (7M)
- b) Explain how an op-amp can be used as an integrator. (7M)
7. a) Draw and explain the input-output characteristics of CE amplifier. (7M)
- b) Explain voltage series current shunt feedback amplifier with near sketch. (7M)



I B. Tech II Semester Regular/Supplementary Examinations, April/May - 2018
BASIC ELECTRICAL AND ELECTRONICS ENGINEERING

(Com. to ME, AE, AME, Min.E, MET)

Time: 3 hours

Max. Marks: 70

- Note: 1. Question Paper consists of two parts (**Part-A** and **Part-B**)
 2. Answering the question in **Part-A** is Compulsory
 3. Answer any **FOUR** Questions from **Part-B**

PART -A

1. a) State and explain ohms law. (2M)
- b) What is meant by Back Emf? (2M)
- c) State the conditions for transformer to be ideal. (2M)
- d) Give the relation between torque and slip of an Induction motor. (2M)
- e) Why is an alternator known as synchronous generator? (2M)
- f) What is P-N junction diode? How its terminals are identified? (2M)
- g) What are the different configurations of transistor? (2M)

PART -B

2. a) Classify different types of network elements. (6M)
- b) Find the equivalent resistance across the terminals A & B of the network shown in figure 2(b) using Y- Δ transformation. (8M)

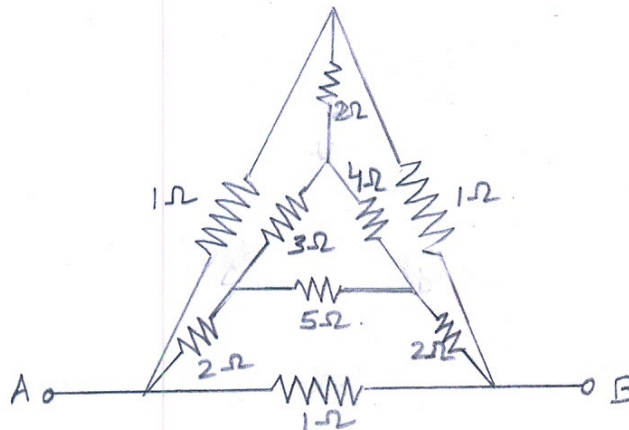
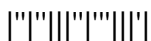
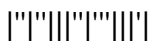

Figure 2(b)

3. a) Explain the Swinburne's test to find the efficiency of a dc generator and a dc motor. (7M)
- b) Explain armature voltage control method of speed control of dc motor. (7M)



4. a) Define transformer efficiency and derive the condition under which it will have maximum efficiency. (8M)
- b) The primary of a 50Hz, step-down transformer has 480 turns and is fed from 6400V supply. Find (i) the peak value of the flux produced in the core, and (ii) the voltage across the secondary winding if it has 20 turns. (6M)
5. a) Explain the principle of operation of a three-phase induction motor. (8M)
- b) A three phase 6-pole induction motor runs at 60rpm on the full load. It is supplied from a 4-pole alternator running at 1500 rpm. Calculate (i) the full-load slip of the motor, (ii) speed of stator held with respect to rotor, (iii) frequency of IM rotor current at full load slip. (6M)
6. a) Draw the circuit diagram of a full wave bridge rectifier and explain its operation with the help of input and output wave forms. (8M)
- b) Compare the characteristics of ideal and practical OP-AMPs. (6M)
7. a) Describe the similarities and dissimilarities in the operation of PNP and NPN transistors. (6M)
- b) Explain the advantages and drawbacks of negative feedback amplifiers. (8M)



I B. Tech II Semester Regular/Supplementary Examinations, April/May - 2018
BASIC ELECTRICAL AND ELECTRONICS ENGINEERING

(Com. to ME, AE, AME, Min.E, MET)

Time: 3 hours

Max. Marks: 70

- Note: 1. Question Paper consists of two parts (**Part-A** and **Part-B**)
 2. Answering the question in **Part-A** is Compulsory
 3. Answer any **FOUR** Questions from **Part-B**

PART -A

1. a) Differentiate between active and passive elements. (2M)
- b) Explain kirchoff's laws with examples. (2M)
- c) Why Swinburne's test is called as no load test? (2M)
- d) Define regulation of a transformer. (2M)
- e) What are the applications of Induction motor? (2M)
- f) What are the disadvantages of centre-tapped full wave rectifier? (2M)
- g) Define α and β of a transistor and give relation between them. (2M)

PART -B

2. a) Two batteries E_1 and E_2 having e.m.fs of 6V and 2V respectively and internal resistances of 2 and 3 ohms are connected in parallel across a 5 ohm resistor. Calculate i) the current through each battery (ii) terminal voltage and (iii) energy dissipated in 5 ohm resistor in 10 minutes. (8M)
- b) In the circuit shown in figure 2(b), find the current through 8 Ω branch. (6M)

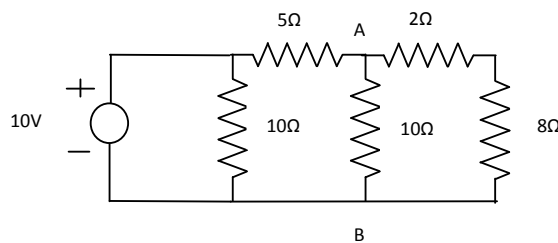
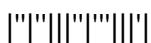
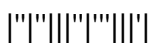

Figure 2(b)

3. a) Obtain the expression for the torque developed by a dc motor. (7M)
- b) A shunt – wound DC generator delivers 46 A at 440 V to a load. The resistance of the shunt field coil is 110 Ω and that of the armature winding is 0.02 Ω . Calculate the emf induced in the armature. (7M)
4. a) Explain the construction and working principle of a single-phase transformer. (8M)
- b) Derive the expression for voltage regulation of a single-phase transformer. (6M)



5. a) Explain the constructional details of a synchronous machine. (7M)
- b) A 6-pole, 3-phase, 50Hz induction motor is running at full load with a slip of 4%. (7M)
The rotor is star-connected and its resistance and reactance are 0.25Ω and 1.5Ω per phase. The e.m.f. between slip rings is 100V. Find the rotor current per phase and p.f., assuming the slip rings are short-circuited.
6. a) Explain the V-I Characteristics of a junction diode when it is forward and reverse biased. (8M)
- b) Explain how an op-amp can be configured as a differentiator. (6M)
7. a) Explain with the help of circuit, the working of a transistor as an amplifier in CE configuration. (7M)
- b) Explain the operation of NPN transistor with neat circuit diagram. (7M)



I B. Tech II Semester Regular/Supplementary Examinations, April/May - 2018
BASIC ELECTRICAL AND ELECTRONICS ENGINEERING
 (Com. to ME, AE, AME, Min.E, MET)

Time: 3 hours

Max. Marks: 70

- Note: 1. Question Paper consists of two parts (**Part-A** and **Part-B**)
 2. Answering the question in **Part-A** is Compulsory
 3. Answer any **FOUR** Questions from **Part-B**

PART -A

1. a) When numbers of resistors are connected in series, show that their effective value increases. (2M)
- b) Classify DC generators. (2M)
- c) Enumerate the various losses that occur in a dc machine. (2M)
- d) Differentiate core and shell type transformers. (2M)
- e) What do you mean by rotor frequency in an induction motor? (2M)
- f) Define Threshold voltage in a P-N junction diode. (2M)
- g) Draw the symbols of PNP and NPN transistors. (2M)

PART -B

2. a) Find the equivalent resistance between the terminals 1 and 2 of the network shown in figure 2(a). (7M)

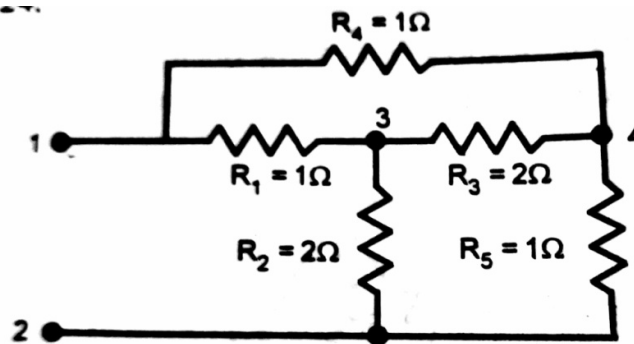
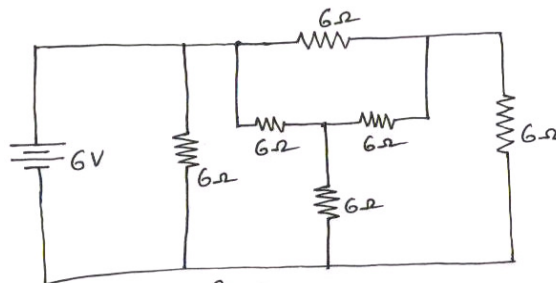

Figure 2(a)

- b) Use star-delta conversion of resistors to determine the current delivered by the battery in the network shown in figure 2(b). (7M)



Figure

Figure 2(b)

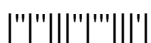

3. a) Draw the diagram of a 3 – point starter and explain the function of each component. (8M)
- b) The induced emf in a dc machine while running at 500 rpm is 180 V. Assuming constant magnetic flux per pole. Calculate the induced emf when the machine runs at 600 rpm. (6M)
4. a) Derive the emf equation of a transformer. (6M)
- b) A single-phase, 50-Hz transformer has 30 primary turns and 350 secondary turns. The net cross-sectional area of the core is 250 cm^2 . If the primary winding is connected to a 230-V, 50-Hz, supply, calculate (a) the peak value of flux density in the core, (b) the voltage induced in the secondary winding, and (c) the primary current when the secondary current is 100 A. (neglect losses). (8M)
5. a) Explain the principle of operation of a synchronous motor. (6M)
- b) A three-phase, 6-pole, 50-Hz induction motor has a slip of 1% at no load and 3% at full load. Find (a) the synchronous speed (b) the no-load speed (c) the full-load speed (d) the frequency of rotor-currents at standstill and (e) the frequency of rotor-currents at full load. (8M)
6. a) Explain the operation of full-wave rectifier with neat sketch and draw its wave forms. (7M)
- b) Explain how an op-amp can be used as a non-inverting amplifier. (7M)
7. a) Explain the operation of PNP transistor with neat circuit diagram. (7M)
- b) Explain the operation of CE amplifier with its frequency response. (7M)

